



FLEECE BEANIE

LEARN TO SEW FLEECE

A LEARNING pattern for beginner sewers



© Pattern Orchard 2017

www.patternorchard.com

#POfleecebeanie

#POlearners

#PatternOrchard

The FLEECE BEANIE pattern

Learn to sew fleece

This pattern has been designed to teach a sewing skill.

The instructions are more detailed than a traditional pattern to better guide you through sewing your first fleece seams.

As you progress through the pattern, the shape and construction method of the beanie introduces you to sewing fleece seams along 2 different types of edges.

About the design

The 5 piece design of this pattern makes the most of your fleece off-cuts.

Sizes to fit the whole family.

The seam allowance for this pattern (how far in from the raw edge your stitching needs to be) is 6-7mm. The width most overlockers sew in from the edge.

Use a medium length stitch (3-3.5)

Table of contents

Fabric guide [page 3](#)

About fleece seams [page 3](#)

Sewing instructions [pages 4-6](#)

Printing instructions are on [page 7](#)



FABRIC

TYPE

For the Fleece Beanie, a polar fleece fabric is recommended. Fleece is often used to make sweaters and track pants. It has a right side that is flat like jersey knit and a high-pile underside that is plush and fluffy.

QUANTITY

Small off-cuts of fleece can be used.

For 1 beanie, less than 20cm of fleece is needed.

It is important that the pattern pieces are positioned with the stretch running across from side to side. < STRETCH >

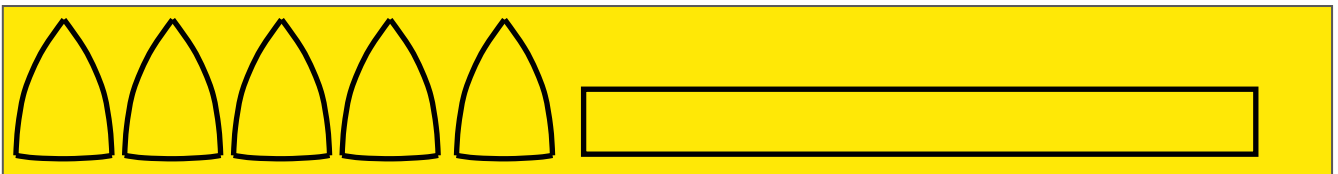

Some seam options are not suitable for use with fleece. (E.g. French seams)

Fleece seams are best sewn on an overlocker, but can be done with a wide, short zig zag stitch on a sewing machine too.

Overlocking does compress the bulk of the fluff as it is sewn.

Trimming away some bulk before turning items inside out can be vital to fleece seams sitting properly.

SEWING INSTRUCTIONS

STEP 1 : Your first fleece seam!

To start, cut 5 tapered triangular pieces and 1 long band.

(a) SEW: Place the 2 triangles right sides together.

Overlock from the bottom edge up to the pointy tip at the top along one side.

(b) REPEAT: Open the sewn triangles and place the next triangle right sides together on top of one of the sewn triangles. SEW from the bottom edge up to the top tip again to join this next triangle to the other joined ones until all 5 are together.

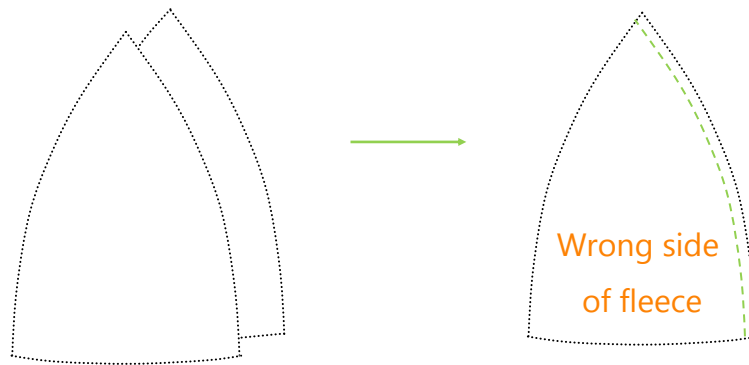

STEP 2: Place the first and last triangle right sides together and SEW from the bottom edge up to the tip again to complete the circle of triangles.

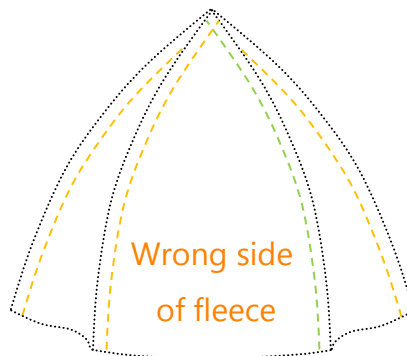

TRIM off a little of the bulk created at the tip where all of the pieces meet.

STEP 3: Fold the band in half right sides together and SEW down the short raw edges.

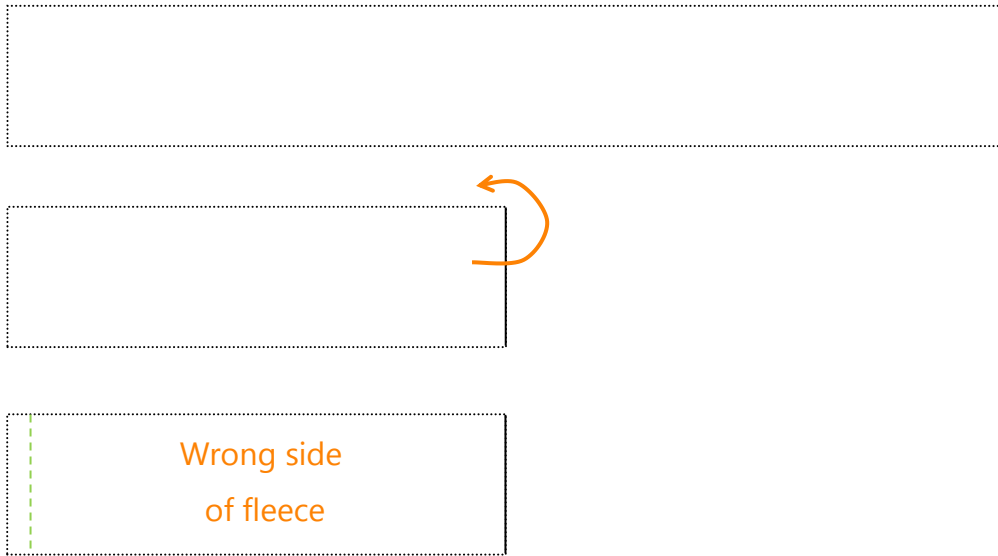

STEP 4: Fold the band in half around the length of it so that the right side is on the outside and the wrong side is completely enclosed inside.

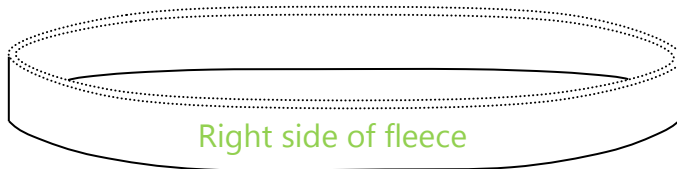

Turn the hat section out the right way and place it inside the band aligning the raw edges.

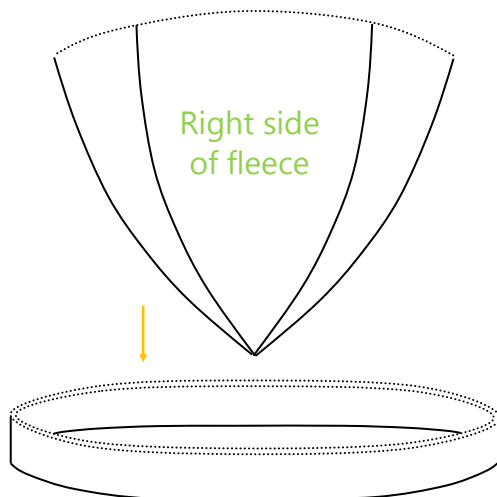

STEP 5: Pin evenly before sewing the band to the hat.

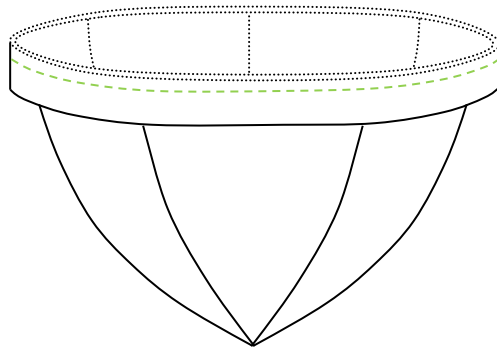

Turn out the right way and you are finished!

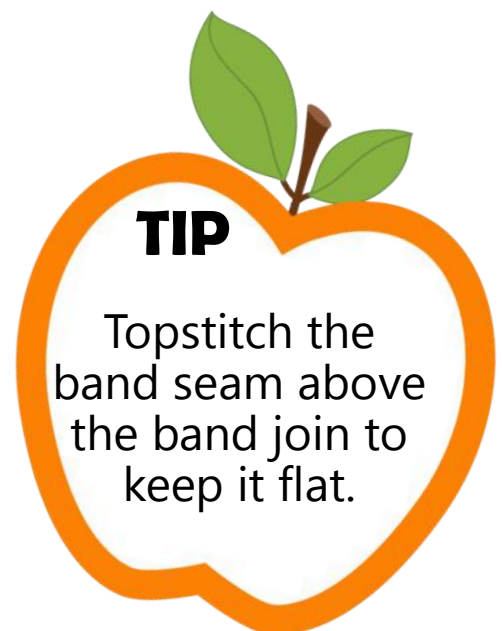
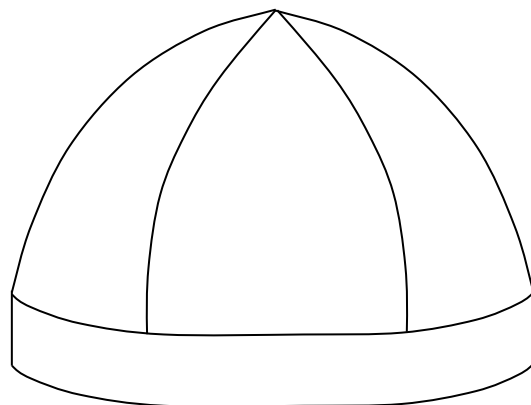

Printing

Print page 8. Using a metric ruler, check that the printed ruler picture on page 8 accurately measures 12cm.

Then print page 9.

If this is not accurate to within 1mm, your page has not printed to scale and you will need to troubleshoot the issue with your printer. Find out more about printing to scale on the Pattern Orchard website at www.patternorchard.com

To save tracing off each size, print the pattern again and cut one copy along each size line. If a pattern piece gets damaged, you can print it again.

On page 9, cut out the two rectangular shapes and join along the dashed green line.

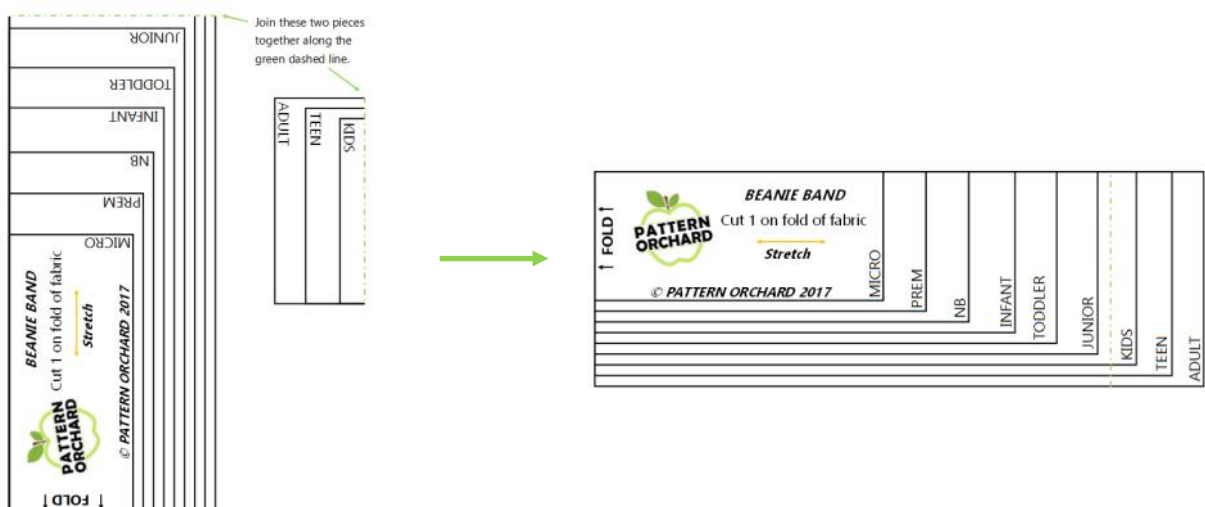

Print this page first and check ruler length.

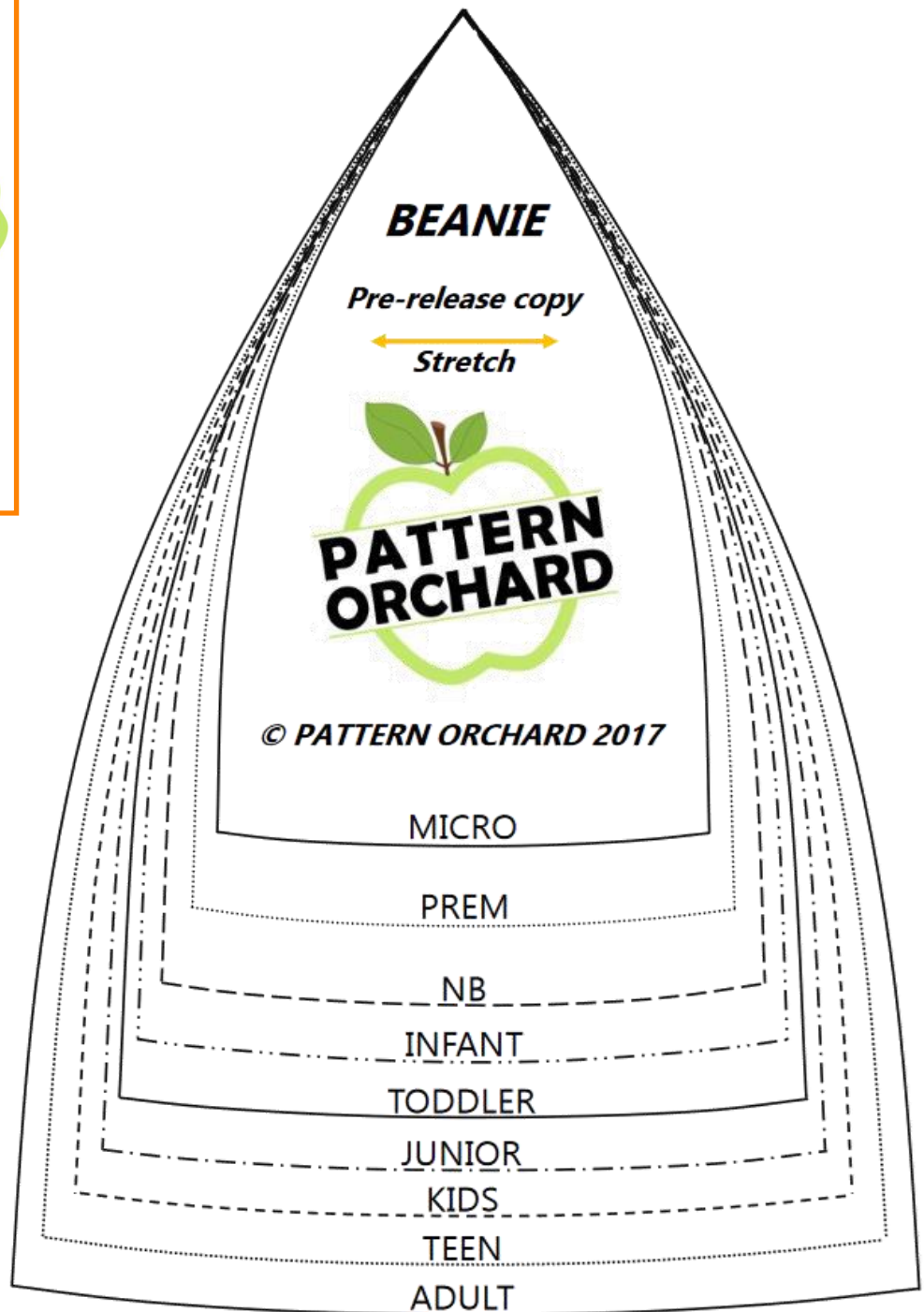
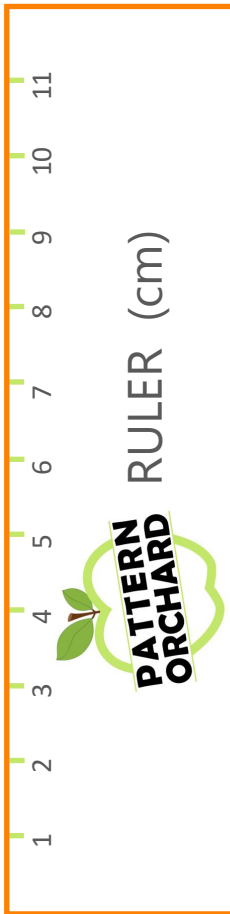

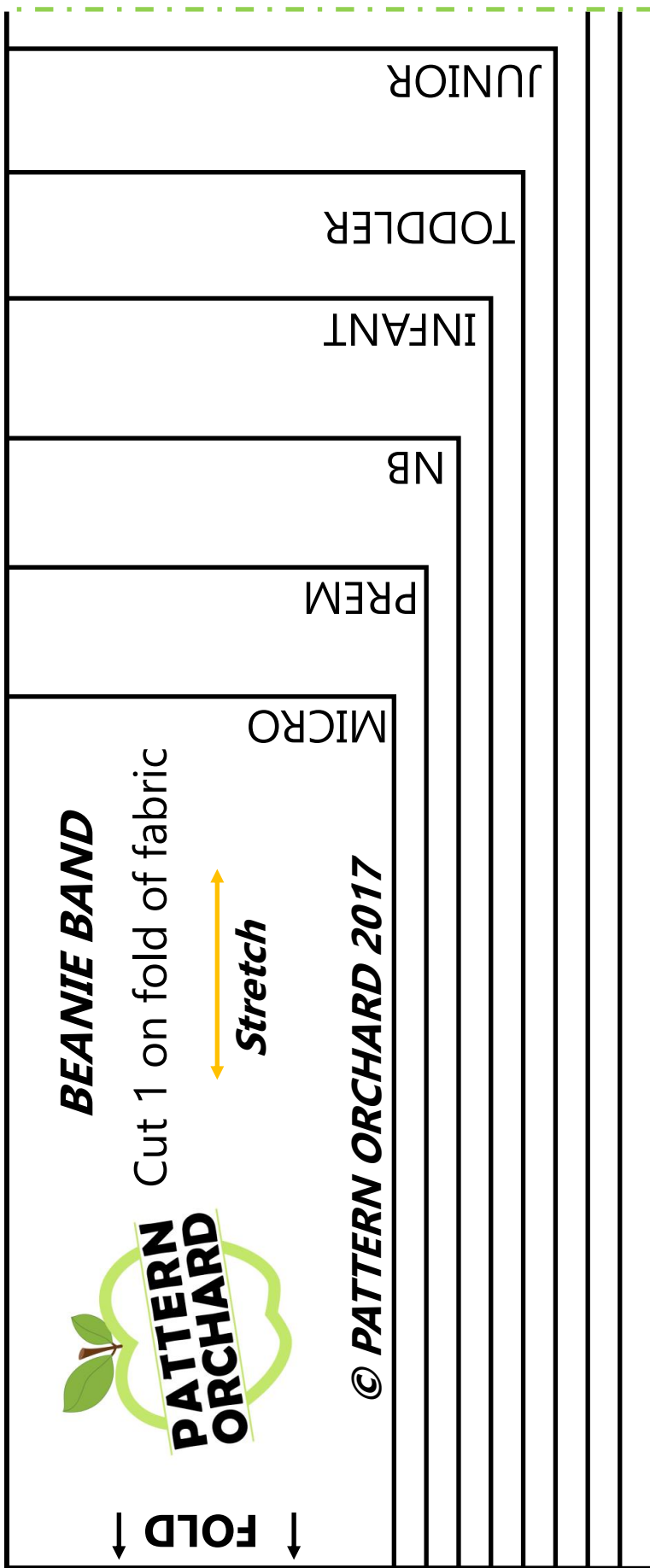

Join these two pieces together along the green dashed line.



To fit head size:

- Micro: 26-39cm
- Prem: 30-34cm
- Newborn: 35-39cm
- Infant: 40-44cm
- Toddler: 45-48cm
- Junior: 49-51cm
- Kids: 52-55cm
- Teen: 56-59cm
- Adult: 60-63cm